

István Mihály,¹ Ferenc Varga²

An Experimental Study of Smoke Movement in a Pressurised Smoke-Free Staircase

Abstract

Pressurised staircases play an important role in ensuring both safe evacuation and conditions for rescue and firefighting intervention. Occupants may be delayed in getting to safety or extinguishing the fire for unforeseen reasons. In some cases, the pressurised staircase or its lobby may serve as a temporary protected area for persons unable to escape independently, which should ensure the safety of the persons fleeing or being evacuated for a limited period of time. In such cases, the role of effective smoke control should be a priority. The purpose of pressurisation is to prevent the entry of smoke and toxic combustion gases at dangerous levels, but the possibility cannot be excluded. In the present series of studies, the smoke flow in a pressurised staircase was investigated in order to gain experience of the characteristics of smoke movement and propagation under these conditions. This involved a series of experiments with smoke cartridges placed on different staircase levels, supported by ventilation measurements to investigate the smoke flow. Based on the results of the measurements and observations, we proposed possible improvements to the technical solutions.

Keywords: pressurised staircases, differential pressure measurements, Pressure Differential Systems (PDS), smoke movement

Introduction

Restricting smoke ingress into pressurised spaces requires a complex approach and practical considerations. The objective of this research is to investigate the smoke

¹ Certified Fire Protection Specialist, Juridical Expert, CEO, Brandplan Kft.; PhD student, Doctoral School of Military Engineering, Ludovika University of Public Service, e-mail: mihaly.istvan90@gmail.com

² Head of Institute of Disaster Management, Faculty of Law Enforcement, Ludovika University of Public Service, e-mail: varga.ferenc2@uni-nke.hu

flow characteristics in an existing pressurised staircase, which requires knowledge of the ventilation characteristics of the staircase. For this purpose the air flow rates, air delivery and air exchange rates into and out of the staircase will be determined prior to the smoke tests.

In the event of fire in mid-rise and high-rise buildings, escape of occupants may be through stairwells or escape windows protected from the effects of the fire. Pressurisation is a common way of preventing smoke from entering stairwells.³

An FDS (Fire Dynamics Simulator) simulation study which investigated the effectiveness of pressurisation as a function of the number of open doors, found that in the tested layout, when more than four doors were opened simultaneously, the pressurised smoke venting system was inadequate.⁴

A key challenge in the design of pressurised staircases is the number of stairwell doors that are assumed to be open at one time when determining the fan working point. In this process, the designer has to take into account the design of the building, the evacuation strategy and the impact of firefighter intervention.⁵

In some buildings, the role of smoke control systems may be subordinate to other purposes (e.g. preventing the escape of toxic fumes), in which case they should be designed with special conditions.⁶

In the case of open stairwell doors with pressurisation, outward airflow may also result in backflow in the direction of the stairwell, which can be detected by smoke flow testing.⁷

Two important elements in achieving effective pressurisation are the provision of adequate overpressure and airflow when the windows are closed or open. It is important not only for the evacuation of the building, but also for the efficiency of firefighting intervention and the ability of the firefighters intervening to secure the scene.⁸

According to the definition of the *National Fire Protection Regulations (OTSZ)* issued by the Decree of the Ministry of the Interior 54/2014 (5.XII.), the possibility of smoke and toxic combustion gases formed during a building fire to enter smoke-free stairwells must be limited, which will allow the building to remain suitable for safe evacuation and rescue for a specified period of time. Smoke control itself is defined as a set of measures to prevent the entry of smoke into a sheltered place to an extent that would endanger escape, i.e. not to exclude the possibility of smoke ingress.⁹

According to the Fire Protection Technical Guideline (TvMI) on protection against heat and smoke spread, in staircases without smoke in the absence of fire, the pressure difference between the staircase and the adjacent space may be equalised, and in some cases the pressure in the adjacent space may exceed the staircase overpressure in the absence of pressure relief, which should be prevented by regulation.¹⁰ Most

³ ALIANTO et al. 2022: 104224.

⁴ LEE-LAU 2023: 132–153.

⁵ International Code Council and Society of Fire Protection Engineers 2022: 210.

⁶ KÁTAI-URBÁN et al. 2023; CIMER et al. 2021.

⁷ MIHÁLY-BÉRCZI 2023: 47–64.

⁸ VARGA 2018: 261–276.

⁹ Decree 54/2014 (5.XII.) of the Ministry of the Interior.

¹⁰ TvMI 3.4:2022.06.13 2022.

designers and experts use solutions based on TvMI-s. The reason is that these solutions are already proven and meet the level of requirements of the OTSZ.¹¹

The Fire Protection Technical Guideline on evacuation provides for the possibility of a smoke-free staircase (pressurised staircase) rest area or smoke-free staircase lobby (pressurised staircase with pressurised lobby) as a temporary protected area. In this case, the staircase or lobby shall be enclosed with fire and smoke barriers appropriate to the risk classification of the building, and shall be protected against fire spread from the facade.¹²

The German VDMA 24188 also differentiates the definition of the minimum air velocity to be provided in the free cross-section of the open door by taking into account the location of the staircase within the building, which is due to the temperature difference between the staircase and the staircase opening in case of fire. In case of some staircase types, where the exhaust air is not extracted or not automatically extracted from the adjacent space, it requires the flushing of the staircase with fresh air at a rate of at least 10 000 m³/h.¹³

When all stairwell doors are closed, a small amount of airflow is sufficient to maintain a smoke-free stairwell.¹⁴ The sizing should also take into account how many doors are open at the same time.¹⁵

Description of the subject of the study

The main parameters of the building containing the staircase under study, based on the field survey

The analysed staircase is a pressurised staircase with a pressurised lobby in a mid-rise community building in Budapest, Hungary. The building has a basement level, ground floor, four floors + roof level, the height of the top use level is +21.62 m, and the height of the lowest use level is -3.25 m in relation to the exit level (ground floor). The building is typically occupied by people who are able to escape on their own, but the presence of people who are able to escape with assistance due to their intended use should be expected.

During the last major reconstruction of the monumental building, the provisions of the National Fire Protection Regulations issued by the Ministry of the Interior Decree 2/2002 (23.1.) were applicable.

The main direction of evacuation of the building is the pressurised staircase, which is separated by fire barriers on all floors. Of the two elevators in the pressurised lobby, one is designed as a firefighting lift in accordance with MSZ EN 81-72 and

¹¹ BÉRCZI 2021: 32–42.

¹² TvMI 2.5:2022.06.13 2022.

¹³ VDMA 24188 2011: 6–15.

¹⁴ BLACK 2015: 216–230.

¹⁵ NFPA 92 2021: 92-8.

MSZ 9113. When designing smoke-free staircases, it was also necessary to take into account the technical regulation ME-04-132-84 of the building sector.

According to the currently valid, repeatedly amended National Fire Protection Regulations issued by the Ministry of the Interior in Decree 54/2014 (5.XII.), the building's standard risk class is MR (medium risk). Due to the difference in level of more than 14 meters, the staircase of the building considered for evacuation should be designed as a smokeless stairway at present. The current requirement for safe access from a smokeless staircase to a safe space cannot be met by the staircase, but there was no such obligation at the time of the conversion.

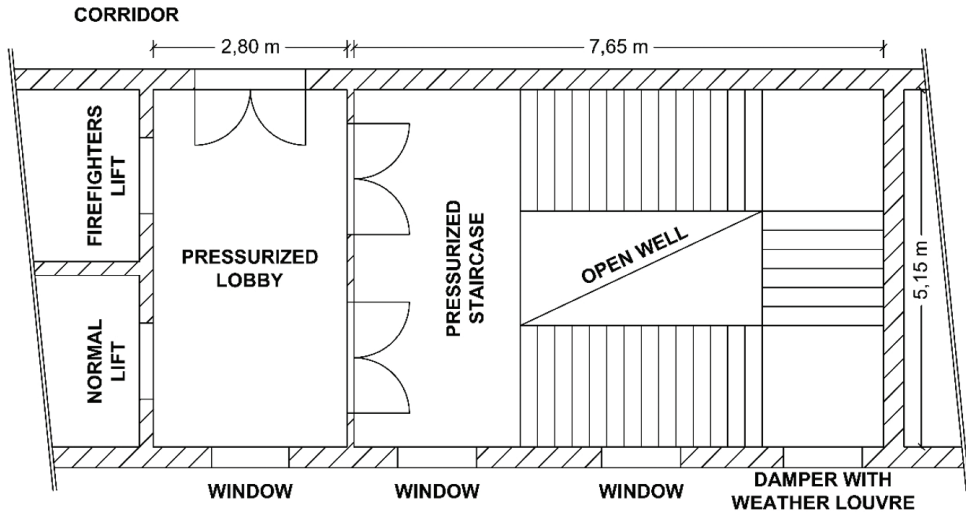

Figure 1: Floorplan of the pressurised stairwell at the 1st floor

Source: compiled by the authors

Main parameters of the pressurisation system based on the on-site survey

The stairwell pressurisation fans are located in a dedicated room on the top floor, with weather louvres on the boundary wall to allow fresh air to be drawn in. The fans supply fresh air to the stairwell at the top level through three openings with a geometric area of 1.44 m² per fan. A fan is also installed on the roof level to the pressurised lobbies. The air intake is provided by an air duct with outlets at each level.

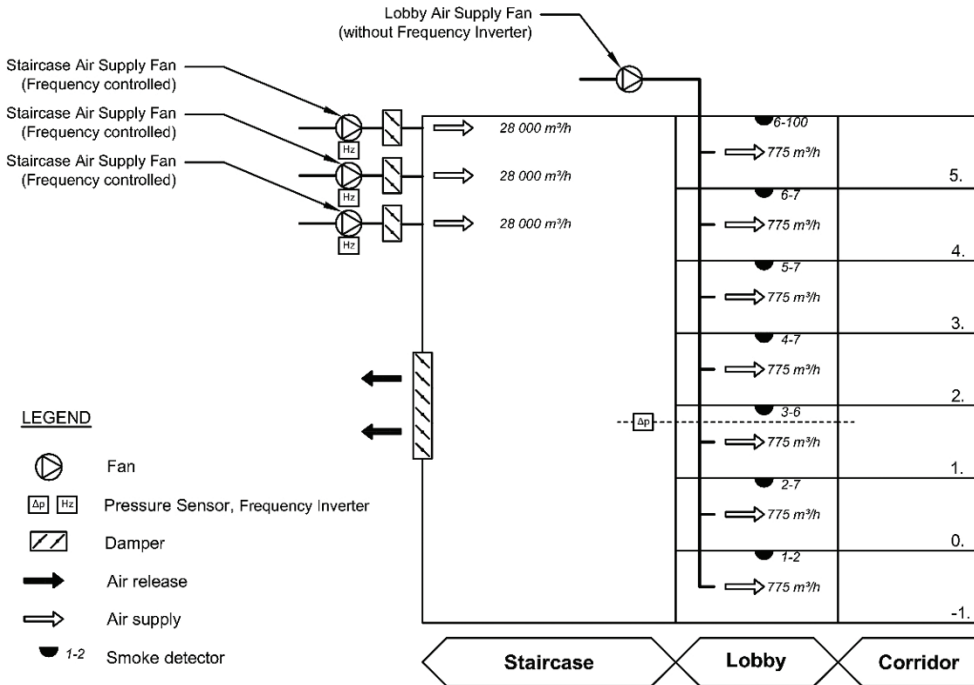

Figure 2: Schematic build of the pressurised stairwell with the designed air volumes of the fresh air
Source: compiled by the authors

The relative overpressure in the staircase is detected by a differential pressure sensor on the first floor between the staircase and the air space of the accommodation. The double-leaf fire doors opening into the staircase have a "non-combustible" flammability rating according to their technical building permit, a certified fire resistance limit value of "TH = 0.5 hours" and an air tightness rating of L4.

The staircase pressure is controlled by PI control with a proportionality factor of 0.5 and an integration time of 10 s, which was not changed during the measurements. The set point was 70 Pa, with a minimum frequency of 10 Hz, which was the same as the start frequency. The designed air volume of each fan was 28 000 m³/h each, with a total pressure of 350 Pa.

On the external facade wall of the staircase, between the ground floor and the first floor, a 1000 × 1920 mm motorised damper with a weather louvre was installed, which provides a continuous airflow to the open air during the operation of the pressurisation system.



Figure 3: Staircase pressurisation fans on the top floor
 Source: compiled by the authors

Ventilation test of the staircase

We have carried out an aerodynamic measurement of the staircase in order to assess the characteristics of the staircase operation. The differential pressure values per level are illustrated in Figure 4. The characteristics of the measuring instruments used in the measurement are summarised in Table 1.

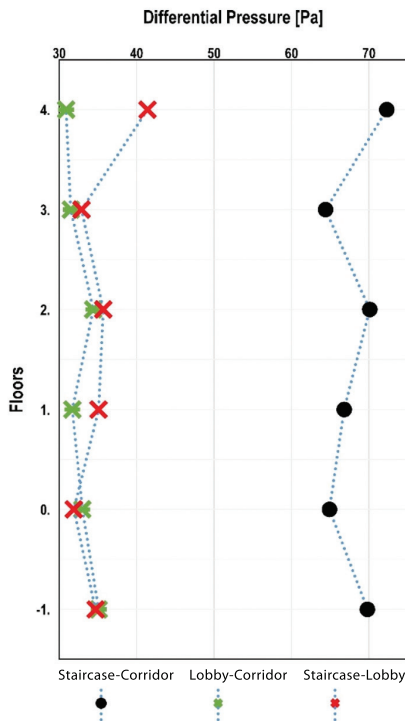

Figure 4: Differential pressure between spaces
 Source: compiled by the authors

Table 1: Instruments used in the measurement

No.	Field of measurement	Type	Measuring range	Accuracy	Resolution	Date of calibration and certificate No.
1.	differential pressure	0560 0400	0–200 hPa	$\pm(0.3 \text{ Pa} + 1\% \text{ of the measured value})$ $\pm 1 \text{ Digit (0 ... 25 hPa)}$	0.001 hPa	10. 10, 2022. 4740014
2.	air velocity	0635 9430	0.3 to 35 m/s	$\pm(0.1 \text{ m/s} + 1.5\% \text{ of the measured value})$ (0.3 to 20 m/s)	0.01 m/s	07. 11, 2022. 224647
3.	temperature	0635 1570	-20 to +70 °C	$\pm 0.5 \text{ °C (0 to +70 °C)}$	0.1 °C	04. 11, 2022. 224648
4.	air velocity	0635 1570	0 to 50 m/s	$\pm(0.03 \text{ m/s} + 4\% \text{ of the measured value})$ (0 to 20 m/s)	0.01 m/s	07. 11, 2022. 224649
5.	humidity	0560 6082	2 to 98%RH	$\pm 2\% \text{ RH (2 to 98\% RH)}$	0.1 %RH	07. 11, 2022. 224650
6.	temperature	0560 6082	-10 to +70 °C	$\pm 0.5 \text{ °C (at +25 °C)}$	0.1 °C	04. 11, 2022. 224651

Source: compiled by the authors

Based on the pressure measurements, the measured pressure values exceed the current regulations, so we have proposed to control the staircase pressurisation system using a reduced setpoint.

The staircase measured was characterised by a damper located between the ground floor and the 1st floor, opening directly into the open air, providing a continuous air flow from the staircase to the open air, regardless of whether the staircase doors are open or closed. Air velocity measurements were taken when the doors on the ground, 1st and 2nd floors were open, and the resulting air velocities were found to provide airflow rates that meet the requirements at the time of installation. The total measured air flow through the openings was 59 998 m³/h, of which 11 186 m³/h escaped through the damper.

Subsequently, the air transport of the staircase air supply system was tested in static condition with closed doors. The aim of the measurements was to obtain data on the amount of air entering the staircase and the amount of air leaving the staircase through the damper before the smoke tests are carried out. The measurements were carried out in three setups. In the first case, the formwork leading to the open air was completely covered with an airtight sheet. Subsequently, further measurements were carried out with uncovered and 25% covered air release opening.

During each series of air measurements, the airflow through the air intakes of the fans was recorded (at 60 points per measurement), the airflow through the outdoor damper (air release opening) when it was not closed (9 and 12 points per measurement), and the relative overpressure between the staircase and the corridor was recorded continuously during the tests, the pressure difference at the damper on the first floor,

the average frequency values displayed by the inverters in the given arrangement. The air velocities measured at the inlet surface as a function of the free surface area of the air release opening and the air volumes calculated from them are summarised in Table 2. The measured values show that the control responded well to the increase in the air release opening surface area, increasing the amount of air introduced. This is confirmed by the values displayed by the frequency inverters (Table 3).

Table 2: Average air velocity at the inlet and the calculated air volume

Free area of the air release opening (%)	Average air velocity at the inlet [m/s] / calculated air volume [m ³ /h]			Total air volume [m ³ /h]
	Fan LB1	Fan LB2	Fan LB3	
0 (closed)	1.08 5035	0.91 4246	1.03 4795	14 076
25	2.81 13 087	1.48 6884	2.39 11 135	31 107
100	2.76 12 877	1.76 8 196	2.37 11 037	32 110

Source: compiled by the authors

Table 3: Displayed value of frequency on the frequency inverter

Free area of the air release opening (%)	Displayed value of frequency on the frequency inverter (FI) [Hz]		
	FI-1 (Fan LB1)	FI-2 (Fan LB2)	FI-3 (Fan LB3)
0 (closed)	23.6–23.7	24.0	23.6–23.7
25	31.0	35.3	34.6–34.7
100	32.7–32.8	35.5–35.6	34.9–35.0

Source: compiled by the authors

Air measurements on the air release opening to the open air were taken at 12 points in the uncovered configuration and at 9 points with the damper at 25% covered. At each point, one measurement sequence was 30 s, with a recording frequency of 1 Hz. The air velocities measured at each point, and the pressure difference between the two sides of the damper while measuring the air velocity, are illustrated in Figure 5. The free aperture area is taken into account by a factor of 0.8.

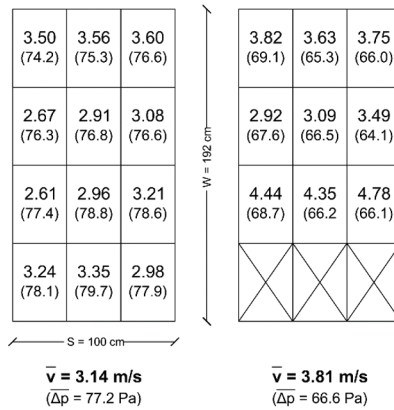

Figure 5: Measured air velocity and pressure difference through the air release opening with 100% and 25% free area of the vent

Source: compiled by the authors

The total gap surface of the staircase was estimated by calculation based on the air volume introduced and the air volume leaving the staircase, which showed a good agreement in the three measurement series even with twice the air volume difference. Its values are summarised in Table 4.

Table 4: Calculated crack area of the staircase

Free area of the air release opening (%)	Average pressure differential between the staircase and the corridor at 1 st floor (deviation) [Pa]	Measured air volume at the air release opening [m ³ /h] (A _{eff} /A = 0.8)	Measured total air volume at the fans [m ³ /h]	Calculated crack area of the staircase without the Area of the air release opening [m ²]
0 (closed)	73.4 (1.89)	≈ 0	14 076	0.354
25	70.6 (1.38)	15 759	31 107	0.393
100	72.9 (1.49)	17 358	32 110	0.372

Source: compiled by the authors

The air measurements show that the staircase is well ventilated even with the doors closed, with an air exchange rate of more than 20 times (23.7 1/h), i.e. about 732 m³ above the air release opening. The amount of air introduced, the fan speed with the doors closed, is sufficient.

Smoke test observations

The aim of the study was to determine the smoke flow characteristics and properties of a pressurised staircase when ventilated with flush air. For this purpose, we carried out three trials. In all tests, the same smoke candle with the same charge and charge volume was used. We took video footage of the rehearsal from two directions. One of the observation points is the ground floor, from which the damper leading to the open air is clearly visible. The second observation point was the 2nd floor during the first and second tests, and the 3rd floor during the third test. From the selected observation points, the smoke flow was well monitored.

In the first experiment, the smoke candle was placed on the basement level of the pressurised staircase, at the centre of the vertical projection of the open well. In the second experiment, smoke was developed on the rest below the air release opening, and in the third case on the rest above the damper.

The nominal weight of the smoke candles used was 200 g. According to the information provided by the smoke candle manufacturer, the main components of the mixture are 1.4-dihydroxyanthraquinone, potassium chlorate and ammonium chloride. The average time of smoke emission during the tests was 89 seconds.

Smoke candle in the basement

In the first experimental arrangement, the smoke candle was installed at basement level, below the air release opening, about 8 meters below it. Within a few seconds, the developing smoke enveloped the staircase to a height of approximately 3 meters from the floor level. At the same time, an intense flow of smoke was observed from the pressurised space towards the pressurised lobby at basement level. The smoke flowing through the gaps around the door was stirred up and diluted by the air inlet to the hallway. The optical smoke detector located here gave a signal 55 seconds after ignition. The smoke in the lobby airspace then leaked into the lift shafts and towards the accommodations.

In the staircase, smoke was flowing upwards from the lower part of the staircase and smoke was also flowing into the pressurised lobby on the ground floor through the doors from the staircase to the lobby. The optical smoke detector located in the ground floor lobby gave a signal at the 106th second.

During the investigation, there was no significant amount of smoke entering the 1st floor lobby, no fire alarm was received from there, but the presence of smoke was detectable by the senses. The resulting smoke was ventilated very slowly through the damper leading to the open air and through the basement and ground floor lobbies. It could be seen that on the side opposite to the inlet, away from the air release opening, the smoke spread rapidly through the gaps, with significant amounts of smoke entering the lower level lobbies. There was no smoke visible to the senses above the air release opening, although there was smoke entering the lobby on the first floor, which was also not significant. In order to ventilate the stairwell space, it was also necessary to open the doors to the corridor at basement level. Smoke was

seen leaking into the firefighters lift shaft. In the elevator cab waiting on the third floor, the smell of smoke was detectable, while on arrival in the basement lobby, when the lift landing door was opened, the smoke was visible entering the car.

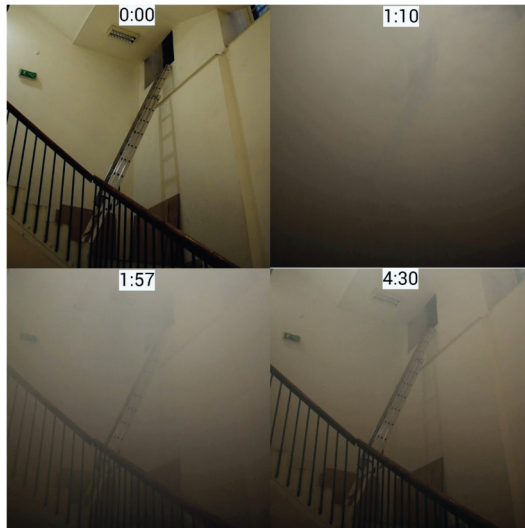

Figure 6: Test 1, observation from the ground floor

Source: compiled by the authors



Figure 7: Test 1, observation from the 2nd floor

Source: compiled by the authors

Smoke candle under the air release opening

In the second experimental set up, the smoke candle was installed on the mezzanine rest in front of the air release opening, 2 meters below it. Some of the evolving smoke was released into the open air, but there was a separation in the open well, which caused the smoke to spread towards the lower levels. After the release ceased, the resulting smoke mass descended as a vapour to the lower floors, where a significant amount of smoke was released through the door gaps into the ground floor and basement lobbies.

During the experiment, smoke was observed in the first floor lobby, but not accumulated to the extent that would have been indicated by the optical smoke detector. The optical sensor located in the ground floor lobby was triggered at second 166, while the sensor located in the basement lobby was triggered at second 210. In this experiment, too, there was evidence of smoke in the shaft of the firefighters lift.

Smoke ventilation from the staircase was faster than in the first test arrangement. This is because some of the smoke has already escaped into the open during the development stage. Ventilation of the lower parts was also possible in this case by opening the doors to the corridor.

The investigation showed that the smoke candle placed closer to but lower than the damper created more favourable conditions in the staircase, but still a significant amount of smoke was released into the lower, unflushed area. There was no smoke visible to the senses above the air release opening, but there was smoke leakage into the firefighters lift shaft. The optical smoke detectors gave a later signal than in the first test, due to the fact that part of the smoke from the staircase had escaped through the dampers to the outside, and therefore the smoke concentration in the lobby was slower to develop.



Figure 8: Test 2, observation from the ground floor

Source: compiled by the authors

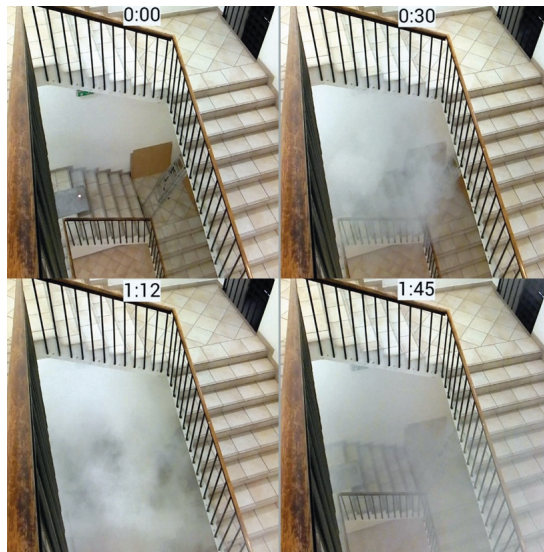

Figure 9: Test 2, observation from the 2nd floor

Source: compiled by the authors

Smoke candle above the air release opening

In the third experimental setup, the smoke candle installed in the rest area between floors 2-3 was located above the air release opening, about 2 m above it. The smoke initially started to flow down the staircase, and then downward flows were observed in the open well. A significant part of the smoke escaped to the open air through the damper, but the outflow was adversely affected by the fact that the opening to the open air was partially covered horizontally by the stairway. The remainder of the smoke descended down the open well as in the second experiment. In the second floor lobby, smoke ingress was only briefly detectable by the senses. In the lower level lobbies, the optical smoke detectors gave a significantly later signal, which can be explained by the dilution of the smaller amount of smoke. The firefighters lift shaft was leaking a detectable amount of smoke. It can be seen that during the smoke development above the air release opening, a significant part of the smoke generated was vented outdoors through the damper. The remainder descended in the open well, but at a lower volume and density compared to the first and second experiment. The levels above the vents remained smoke-free, but smoke reached the lower levels. The small amount of smoke that entered the lobby slightly penetrated the firefighters lift shaft.



Figure 10: Test 3, observation from the ground floor
Source: compiled by the authors

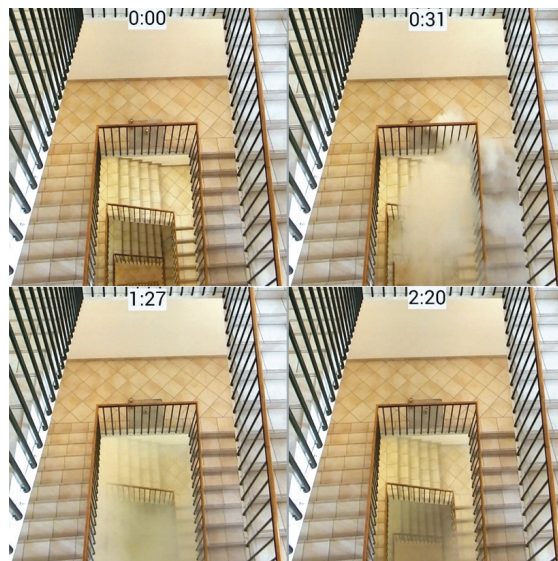

Figure 11: Test 3, observation from the 3rd floor
Source: compiled by the authors

Summary

The levels above the air release opening (damper) remained smoke-free throughout the tests, and with the smoke candle above the damper, smoke did not flow to the area above the smoke candle, meaning that the smoke-free airspace with effective flushing was permanent. This is also due to the roughly 20-fold increase in air exchange in the airspace above the damper, as measured.

In all cases, the smoke was trapped on the levels below the damper, and the smoke flowed through the gaps in the doors into the lower pressure connected spaces. The ventilation of lobbies with lower pressure compared to the staircase stirred up the smoke from the staircase, which in several cases led to the alarm of optical smoke detectors in the lobbies.

A small amount of smoke entered the firefighters lift shaft and the car. This was partly achieved through the gaps around the closed lift landing door, and when the lift landing door was opened, a larger volume was able to flow into both the car and the lift shaft.

Smoke flow into the lift shaft was facilitated by the higher pressure in the lobby compared to the lift shaft. Furthermore, the ventilation opening in the upper part of the lift shaft resulted in a greater chimney effect in the shaft due to the significant temperature difference. During the tests, the outside temperature was 1.9 °C, while the temperature in the staircase was 20.1 °C at the start of the measurements.

Conclusions and recommendations

Based on the tests performed, a fire in the stairwell is a significant risk factor, as the pressurised ventilation will cause smoke to be vented to rooms with stairwell connections away from the fire source, through gaps around the doors.

Smoke can enter a pressurised staircase, even if the installation and use rules are respected, for the following reasons:

- During a simultaneous evacuation, if the staircase for escape is designed as a pressurised staircase, the air velocity required to expel the smoke cannot develop in the door cross-section due to the open condition of the vast majority of the staircase doors
- During a staged evacuation, if the overpressure in a stairwell is briefly or permanently reduced, smoke may leak in through the gaps of closed door(s). This may occur, for example, when evacuating floors above the level affected by fire if evacuation of floors below ground level is also taking place or if more doors than planned are left open
- During the firefighting, for reasons necessary for the intervention, several stairwell doors are open
- Existing staircases open directly into utility spaces (e.g. offices) or other rooms from which air is not or not efficiently ventilated
- Extreme environmental conditions (wind, temperature difference between the staircase and its surroundings)

- Pressurised staircase with overpressure in accordance with point 11.6.6 of the TvMI. In this case, it is proposed to prohibit the creation of temporary protected areas in the pressurised staircase or in its lobby

Smoke or toxic combustion gases can be expected to enter the staircase in the following cases:

- In the event of a fire in a smoke-free stairwell or its lobby (non-compliance with the rules of use)
- Lack of integrity of the building structure enclosing the smoke-free staircase or its vestibule (missing or inadequate sealing of subsequent wall and/or slab penetrations). The wall or slab between the pressurised staircase and the adjacent spaces without pressurised ventilation shall be sealed with a (fire blocking) barrier that cannot withstand static or increased transient overpressure without damage, with particular attention to integrity
- If mechanical heat and smoke extraction and mechanical air supply are used on the fire affected floor, and the failure of the smoke extraction system causes the associated space to become over-pressurised as opposed to the desired balanced or depressurised pressure conditions

Smoke ingress can pose a risk to persons escaping and, in the case of pressurised stairwells designed as temporary protected areas, to persons in the temporary protected area. Smoke penetration that can be felt by the senses can lead to a panic situation.

An air release opening on the opposite side to the intake proved to be effective in removing smoke from the upper floors, but in all cases smoke was able to reach the areas below the air release opening. It is therefore important that the air release opening is located on the opposite side of the airspace to be kept smoke-free from the intake, otherwise smoke can accumulate in areas without effective ventilation.

Article 190 (2) of the National Fire Protection Regulation is correct, according to which all storage is prohibited in the fire lobby, smoke-free stairwell and lobby.

Section 5.1.2 of standard MSZ EN 81-72 refers the design of smoke protection for firefighters' lifts to national regulations and gives criteria for smoke protection in Annex I, point 17.¹⁶ The National Fire Protection Regulations does not prescribe heat and smoke extraction and pressurisations for firefighters lift shafts, but it does specify that the shaft may only be connected to a room or open space protected against the spread of fire. The MSZ 9113 standard requires a ventilation opening in the shaft head with a cross-section equal to 1 or 4% of the horizontal section of the shaft, depending on the design of the firefighting lifts.¹⁷

The chimney effect created by a standard sized ventilation opening can contribute to smoke ingress into the firefighters lift shaft in case of high temperature differentials, and it is therefore recommended to investigate the need for smoke venting of firefighters lift shafts. It is also important to consider that if the firefighters lift opens into a fire lobby with pressurisation and the lobby pressurisation is only sized to cover

¹⁶ MSZ EN 81-72 2020: 12–13, 45.

¹⁷ MSZ 9113 2003: 4.

the gap losses near the closed doors, there may be a real risk of smoke entering the firefighters lift shaft.

Where a pressurised staircase or pressurised lobby is designed as a temporary protected area to reduce risks, including the risk of panic, it is recommended that smoke-free staircases should have a ventilation surface sized to the air exchange rate to ensure its ventilation. This will remove any smoke from the stairwell. Safety can be further enhanced by locating the temporary protected area in the airspace of the pressurised staircase and creating a pressurised lobby between the staircase and the accommodations (a pressurised staircase with lobby).

Pressurised ventilation of firefighters lift shafts can be used to limit smoke ingress into the lift shaft. Pressurised ventilation of normal lift shafts in the event of fire can reduce the spread of smoke through lift shafts.

Increased emphasis should be placed on the monitoring of compliance with the provisions of Article 190 (2) of the National Fire Protection Regulation during official controls. In addition, it is recommended that the electrical wiring and cables installed in the staircase should be classified as at least class s1 for smoke emission according to MSZ EN 13501-6. The national MSZ 13207:2020 Annex C and the TvMI on electrical installations, lighting protection and protection against electrostatic discharge Annex B.2.6 also contains a requirement for cables, but only for certain types of buildings, and does not include the temporary protected area.¹⁸

Where open office spaces are connected to a staircase with a pressurised lobby, in addition to the design proposed in the TvMI, consideration should be given to providing an average air velocity of 2 m/s in the free cross-section of the open door to ensure that smoke and other toxic combustion products can be effectively expelled in the event of a full-blown fire.

According to point 5.2.1 of the TVMI on the planning, design and installation of fire alarm systems, the smoke-free staircase and its lobby cannot be considered a low-risk area, i.e. it cannot be excluded from the protection.¹⁹ Based on our investigations, it is recommended, in accordance with Annex C of the TVMI, that the staircase pressurisation system should not be triggered automatically when the first fire alarm is received from the pressurised staircase.

References

- ALIANTO, Beline et al. (2022): High-Rise Building Fire Safety Using Mechanical Ventilation and Stairwell Pressurization: A Review. *Journal of Building Engineering*, 50, 104224. Online: <https://doi.org/10.1016/j.jobe.2022.104224>
- BÉRCZI, László (2021): The Role of Fire Protection Technical Guideline in the Protection against Heat and Smoke Spread. *Védelem Tudomány*, 6(3), 32–42.
- BLACK, William Z. (2015): Stairwell Pressurization and the Movement of Smoke during a High-Rise Fire. *ASHRAE Transactions*, 121(1), 216–230.

¹⁸ MSZ 13207 2020: 86; TvMI 7.5:2022.06.13: 78–79.

¹⁹ TvMI 5.3:2022.06.13.

- CIMER, Zsolt et al. (2021): Application of Chemical Monitoring and Public Alarm Systems to Reduce Public Vulnerability to Major Accidents Involving Dangerous Substances. *Symmetry*, 13(8), 1528. Online: <https://doi.org/10.3390/sym13081528>
- International Code Council and Society of Fire Protection Engineers (2022): *Fire Safety for Very Tall Buildings: Engineering Guide*. The Society of Fire Protection Engineers Series. Cham: Springer. Online: <https://doi.org/10.1007/978-3-030-79014-1>
- KÁTAI-URBÁN, Lajos et al. (2023): Examination of the Fire Resistance of Construction Materials from Beams in Chemical Warehouses Dealing with Flammable Dangerous Substances. *Fire*, 6(8), 293. Online: <https://doi.org/10.3390/fire6080293>
- LEE, Ann – LAU, Ghar Ek (2023): Smoke Control in High-Rise Residential Buildings with Stair Pressurization Systems. *Fire*, 6(4), 132–153. Online: <https://doi.org/10.3390/fire6040132>
- MIHÁLY, István – BÉRCZI, László (2023): Túlnyomásos füstmentes lépcsőházak légtechnikai méréseinek tapasztalatai II. *Védelem Tudomány*, 8(1), 47–64.
- MSZ 9113:2003 Establishment of lifts. Additional requirements for lifts in case of a fire in a building. Magyar Szabványügyi Testület, 2003.
- MSZ 13207:2020 Selection, laying and current rating of power cables and control cables with rated voltages from 0.6/1 kV up to 20.8/36 kV. Magyar Szabványügyi Testület, 2020.
- MSZ EN 81-72:2020 Safety rules for the construction and installation of lifts. Particular applications for passenger and goods passenger lifts. Part 72: Firefighters lifts. Magyar Szabványügyi Testület, 2020.
- NFPA 92: Standard for Smoke Control Systems. National Fire Protection Association, 2021.
- TvMI 2.5:2022.06.13. Fire Protection Technical Guideline Protection. Evacuation. 2022.
- TvMI 3.4:2022.06.13. Fire Protection Technical Guideline. Protection against heat and smoke spread. 2022.
- TvMI 5.3:2022.06.13. Fire Protection Technical Guideline. Planning, design and installation of fire alarm systems. 2022.
- TvMI 7.5:2022.06.13. Fire Protection Technical Guideline. Electrical installations, lightning protection and protection against electrostatic discharge. 2022.
- VARGA, Ferenc (2018): Assessment of the Procedural and Technical Conditions for the Hungarian Fire Investigation System in Line with International Experiences. *Hadmérnök*, 13(4), 261–276.
- VDMA 24188:2011-06 (2011): *Rauchschutzmaßnahmen in Treppenträumen – Rauchableitung, Rauchverdünnung, Rauchfreihaltung*. Verband Deutscher Maschinen- und Anlagenbau e.V. (VDMA), Frankfurt/Main.

Legal source

Decree 54/2014 (5.XII.) of the Ministry of the Interior on the issuance of the National Fire Protection Regulation