

Driving systems of unmanned air vehicles

ANDRÁS FÜLEKY

Miklós Zrínyi National Defence University, Budapest, Hungary

The appearance of air vehicles and their mass application offered a wide range of possibilities in the field of reconnaissance and modern warfare. In addition to manned aircraft designed for reconnaissance purposes, in the 1990's a new family of air vehicles were developed: UAVs were designed.

The paper is to provide an overview of engines applied in UAVs and their application in various types of air vehicles. I will also explore the advantages and disadvantages of these engines.

Introduction

The aim of this paper is to provide an overview of engines applied in UAVs and their application in various types of air vehicles. I will also explore the advantages and disadvantages of these engines.

The appearance of air vehicles and their mass application offered a wide range of possibilities in the field of reconnaissance and modern warfare. In addition to manned aircraft designed for reconnaissance purposes, in the 1990's a new family of air vehicles were developed: UAVs were designed.

The need for UAVs is underlined by numerous factors, such as:

- Risk of losing well-trained, experienced pilots;
- When the air vehicle becomes inoperable over enemy territory, its personnel does not have to be rescued;
- Operability in search-and-rescue missions and in heavy duty circumstances;
- Maneuverability of UAVs is not limited by the pilots' physiological limits, in case of UAVs the limits are solely technological;
- Suitable for establishing radio connection via using the UAV as a radio transmission device;
- Suitable for reconnaissance missions over territories charged by radiological, biological or chemical contamination, without putting human beings at risk;
- Suitable for transmitting real time atmospheric and meteorological images;
- Suitable for wide-range reconnaissance missions requiring high mobility and flexibility;

Received: October 4, 2004

Address for correspondence:

ANDRÁS FÜLEKY
Aradi vértanúk útja 88.
H-1213 Budapest, Hungary
E-mail: tszilvi@kth.bme.hu

- Acquisition, maintenance and repair expenses of a UAV are well below the level of expenditures on a manned air vehicle with similar operational capabilities;
- Continuous operation of reconnaissance air vehicles is of considerable costs;
- Due to the development of micro-electronics UAVs achieve similar or better reconnaissance outcomes than conventional devices;
- UAVs have better anti-reconnaissance indicators;
- Operation of certain UAVs does not require professional assistance, making them widely applicable; this achieves platoon – individual soldier application.

One of the most important challenges of electronic warfare is the problem of placing its devices to the right environment. With the advancement of the capabilities and flight parameters of carrier devices more and more electronic operational instruments may be placed on UAVs. Due to the progress of the equipment of aviation technology and electronic warfare and to the decreased size and energy intake thereof, more UAVs may carry instruments for reconnaissance, support and interruption. These findings clearly indicate the reasons for dealing with the development and application of UAVs.

Classification of UAVs, as air vehicles

As the title of my paper suggests, I am dealing with a rather narrow aspect of UAVs: driving systems of UAVs, in particular. In order to provide a proper overview of the field, first we need to draw up a classification of UAVs and of engines for UAVs.

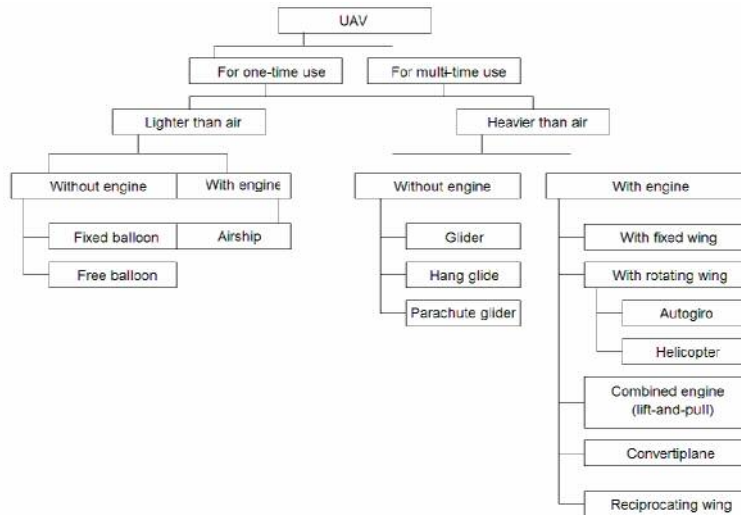

Figure 1: Classification of UAVs

Engines

Currently the following types of engines are being used or designed in an experimental phase for UAVs:

Aerobe engines:

- Inner combustion piston engine with propeller;
- Inner combustion piston engine with rotating blade;
- Jet engine with rotating blade;
- Jet engine with propulsion.

Anaerobe engines:

- Rocket engine with propulsion;
- Electric engine with rotating blade;
- Electric engine with reciprocating wing;
- Reciprocating chemical-muscle.

An optimal engine used in an UAV shall meet the following criteria:

- High specific power;
- Fuel efficiency;
- Light weight;
- Silence;
- Smooth running;
- Reliability;
- Easy to maintain;
- Low production cost.

One of the utmost challenges in developing UAVs is to enhance their flight parameters, including flight time and distance, maneuverability, and the quest for all-weather capability. Developments aim to reduce the specific fuel consumption of driving systems, while enhancing the aerodynamic features and seek to decrease the size, weight (payload), as well as energy consumption (fuel or electricity) of reconnaissance, data-recording, data-transmission and other devices placed on UAVs. This results in a reduction of the size of carrier devices, making them more efficient in performing their tasks. Lighter vehicles and more advanced driving systems have prolonged the patrol time of UAVs from a few hours to dozens of hours in case of certain devices. The reduction of the size and weight of on-board equipment devices (payload) results in the increase of fuel storage space, or in the improvement of the thrust/drag-to-weight ratio. Selecting a driving system, which corresponds best with the task to be performed is of utmost significance.

One of the most important tasks of development is to increase the anti-reconnaissance features of UAVs, thus extending their survivability. This is usually achieved via reducing radar reflecting surfaces, stealth technologies and reducing noise and heat emission of engines and other equipment.

Combustion engines

In the case of propeller and rotating wing drives, increasing airflow touching the surface of the blades produces drag. The propeller or the rotating wing is operated by a combustion engine, which uses surrounding air as a source of power. Such a propeller-based engine fits best slow UAVs, up to a speed of 400 km/h.

In UAVs the application of IC piston engines has various advantages. Its low costs and relatively low operational costs are met with a torque curve, which is beneficial at low-speed flights. Its maintenance, however, is somewhat difficult in winter conditions.

The following is an example of an IC piston engine suitable for a modern UAV, with special attention on its cross-section and various data.

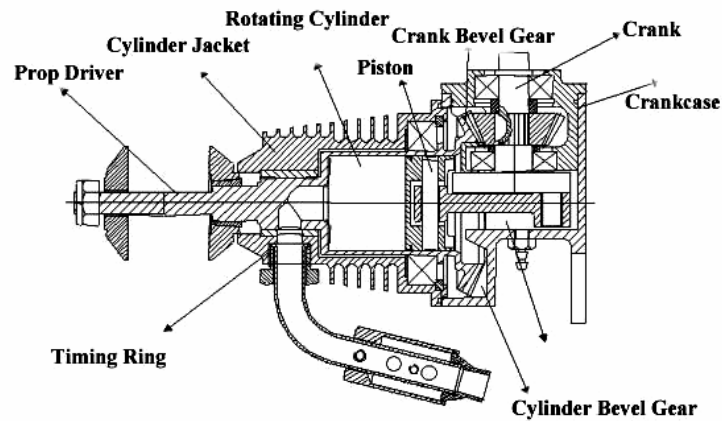

<p>SINGLE CYLINDER, 4-STROKE CYCLE</p> <p>Cylinder capacity: 20.02 cm³ Weight: 1063.4 g Compression: 10.5 Performance: 1,8 HP at 5,800 rpm</p>	
--	--

Figure 2: Cross-section, data and picture of an inner combustion piston engine

Jet engine

Jet engines became a viable option for UAVs with the development of micro-engineering and fluid mechanics (hydrodynamics).

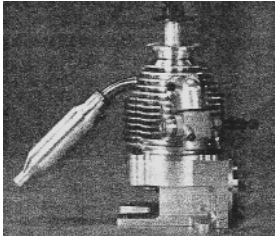

Figure 3: Jet engine using UAVs

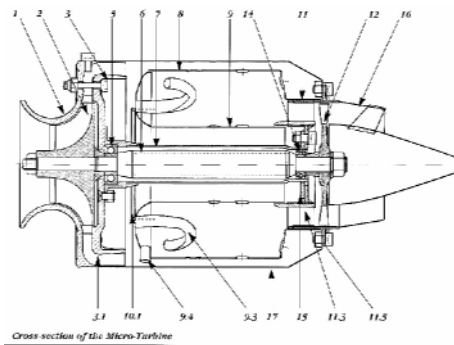

<p>Thrust: 85 N Weight: 1400 g Maximum exhaust gas temperature: 1070 K In-take mass flow: 260 g/min</p>	
--	--

Figure 4: Cross-section, data and photo of micro-turbine

The main parts of a GT jet engine are its intake pipe, compressor, combustion chamber, turbine and exhaust pipe. In order to drive the compressor, the turbine transforms part of the energy from the fuel burnt in the compressed air of the combustion chamber, while the rest is transformed into kinetic energy in the exhaust pipe and provides thrust. Jet engines are used in medium and high speed UAVs, up to the range of approx. 2–2.5 Mach.

The advantage of gas turbine stems from its performance-to-weight ratio and reliable operation; its acquisition and maintenance, however, are rather expensive and require professional skills.

The following provides some illustration:

<p>Diameter: 120 mm Length: 270 mm Engine weight: 2300 g Thrust: 170 N @ 110,000 Maximum rpm: 112,000 Mass flow: 410 g/sec @ 170N Max. EGT: 700°C Fuel: Kerosene – Paraffin – Jet A1 – White Spirit</p>	
--	---

Figure 5: Jet engine type AT-400

<p>Diameter: 100 mm Length: 220 mm Engine weight: 1400 g Thrust: 88 N @ 149,800 Maximum rpm: 153,000 Mass flow: 250 g/sec @ 88N Max. EGT: 700°C Fuel: Kerosene – Paraffin – Jet A1 – White Spirit</p>	
--	--

Figure 6: Jet engine type Mercury HP

Diameter: 120 mm Length: 264 mm Engine weight: 2100 g Thrust: 157 N @ 117,000 Maximum rpm: 120,000 Mass flow: 375 g/sec @ 157N Max. EGT: 675°C Fuel: Kerosene – Paraffin – Jet A1 – White Spirit	
---	--

Figure 7: Jet engine type Pegasus HP

Rocket engine

The driving systems discussed so far relied on atmospheric air as an essential component of fuel, or as exhaust gas volume, or both. These are usually referred to as aerobic engines. Engines which do not require air as a fuel component or gas volume for their operation belong in another category.

Rockets are special jet engines, which carry on board fuel and oxidizing agents for their operation. Chemical, solid fuel rocket engines are preferred as there is considerable information on the operation and application of such engines; these are simple, light and may be manufactured relatively easily and at low costs.

The operation environment of chemical, solid fuel rocket engines is high-temperature gas, which is produced by burning or decaying fuel.

The structure of solid rocket engines is rather simple. Solid fuel – most often gunpowder – is placed in a load in the chamber, so the chamber becomes the fuel container and the rocket's body at the same time.

The advantages are as follows:

- The device and its manufacturing is relatively simple and low-expenditure;
- The powder charge (load) can be stored in the rocket permanently;
- Preparation for launch takes a short time.

The disadvantages are as follows:

- As during the operation of the rocket the chamber storing the load becomes the burning chamber which also happens to be the body of the rocket, during construction extreme pressure (15–20 MPa) and temperature conditions must be taken into consideration as a larger burning chamber might be required;
- Relatively small thrust, which is sufficient for the purposes of UAVs;
- The burning process is significantly affected by the initial temperature of the charge;

- Stopping the engine is difficult or impossible. Since rockets are used for launching UAVs, the size of the charge determines the height of the flight.

Rockets are used to launch UAVs to the height required to commence patrolling. The body of the rocket may be separated from the UAV upon extinction. At such height, the mission may commence with the automatic opening of a closed, variable sweep wing. Alternatively, the UAV may glide, or operate with an electric engine with an opening pitch providing drag for flight.

The application of a solid fuel rocket engine is supplemented by significant noise and light effects, therefore, it may predominantly be used in cases where the rocket can take position rapidly while the covert launch theater may be uncovered without further problems.

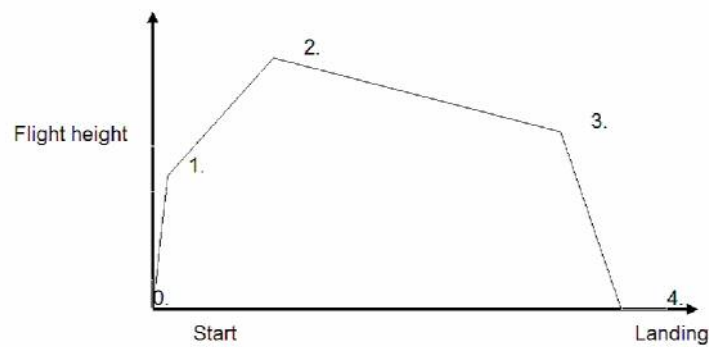

Figure 8: Trajectory curve of a UAV launched with progressive ignition start rocket. 0–2 Launch rocket operates; 2–3 Completion of mission; 3–4 Return maneuver.



Figure 9: Launch of a propeller UAV from rocket launcher

Electric motor

In recent years, significant, on-going developments in the field of electric motors and high capacity batteries made possible the application of air vehicles with electric drive. Today the weight-performance ratio of electric motors and the batteries supplying them is so satisfying, that small-size electric aircraft have become a reality for carrying various sensors and equipment. The operation of small-size electric aircraft is significantly more silent than that driven by an IC piston engine or jet engine: low noise levels and simple maintenance are clear advantages. A further advantage of electric drive is that the motor may be simply stopped and restarted mid-flight. Currently the range and loading capacity of UAVs using traditional IC piston engine exceed vehicles with electric motors. At the same time, there are numerous tasks with a mission time of approx. 50–100 minutes where using a UAV with an electric motor which is capable of carrying a payload of 500–1000 grams is more cost efficient. With the rapid advancement of technology such limits will soon be extended.

The endurance of electric motors with collector brushes and permanent magnets is significantly reduced when they operate at their full operational capacity. Heat is generated by current drain resulting in the magnets' reduction of strength and, consequently, a considerable drop in at a constant rate of current supply. In short, the efficiency of the motor is compromised. High current also triggers premature failures in the commutators, thus crushing the motor.

Three-phase, brushless electric engines are pretty favorable. They require special electric controls, which transform direct current supplied by the battery to three phase alternate current. The efficiency of transformation, due to developments with modern semi-conductors, is extraordinary. The torque of electric motors is high even at low RPM. Comparing two motors of similar size, weight and current drain, the performance of a brush-less motor is 80–100 per cent higher than the performance of a traditional electric motor with a collector brush. UAVs with brush-less motors may either carry a heavier payload or have significantly better flight characteristics. This means that they respond better to turbulence and stronger winds, expanding the limits of the UAV's weather capacities.

Flight time depends on the type of battery selected. Most often NiCd and Li-ion batteries are used. NiCd batteries provide highest current. Li-ion batteries have the best weight-to-performance ratio, but these batteries get overheated at extreme current and fail.

Necessary capacity is calculated upon mission time and motor type. This, however, is not sufficient to determine the proper type of battery. It is important to note that batteries supply their disclosed nominal performance among special, laboratory

conditions. Motors of air vehicles might, however, require 20–40 Amperes. At such current rate, small-size NiCd cells perform well below their nominal performance.

The electric motor may drive the propeller directly, i.e. direct drive. The RPM of an electric motor with collector brush is in the range of 15000–25000 RPM. Although the RPM is high, the peripheral speed of a propeller of 10 cm in diameter is 470 km/h, a figure that is not high. The basic problem of direct drive is the motor’s relatively low torque. The motor cannot reach its nominal RPM due to the propeller’s resistance. The current drain of a motor which operates below its nominal RPM is higher, which also generates more heat. As a consequence, the efficiency of the motor is reduced. In case of direct drive the propeller has to be chosen as follows: at full control the motor’s RPM shall be higher than 80 per cent of the nominal RPM.

As the above indicate, it is advisable to opt for the highest possible RPM. This can be achieved via inserting a driving system between the motor and the propeller axis. Typically these driving systems are cogwheel reducers, which keep the propeller’s RPM low while the motor’s RPM stays high. As a result, the torque at the propeller will be higher, making possible the application of a propeller of larger diameter and higher geometric pitch angle. In the case of such drives the air vehicle is capable of more dynamic elevation, while its maximum speed also exceeds that of equipment with direct drive.

The following is a presentation of a few examples and advantages of electric motors applied in UAVs:

<ul style="list-style-type: none"> • High torque output; • High speed close to 100000 RPM. 	
--	--

Figure 10: Gear motor

<ul style="list-style-type: none"> • High speed up to 75000 RPM; • Excellent power-to-weight ratio. 	
---	--

Figure 11: Brushless DC motor

Both gear and brush-less DC motors are acknowledged for the following:

- When installed in an air vehicle, they provide small face drag;
- Designed for long life and high reliability;
- Flexible design for optimum application performance.

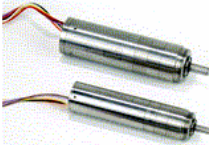
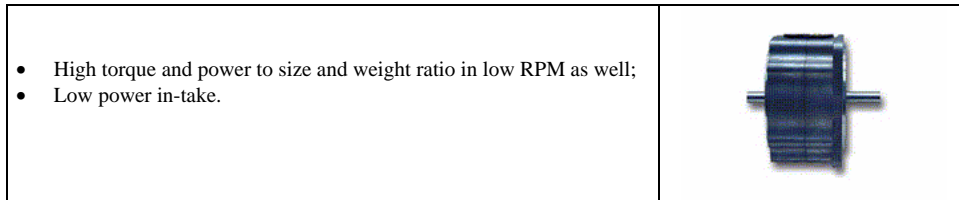

Figure 12: Discmotor

Chemical muscle

On the achievements of hydro-bionics scientists in the U.S. and U.K. designed a UAVs with reciprocating wings, in which the alternating movements of a chemical muscle realize the periodic movement of the wings.

The concept of the air vehicle is the following: kinetic energy necessary for the thrust is generated in the RCM (Reciprocating Chemical Muscle), which can generate automatic wing movements from a chemical energy source.

Mixed engine

Mixed engines are advantageous not so much for reasons of practical application; rather, they increase the survivability of the air vehicle. For the case of a failure of the primary engine it was imperative to find a solution, that enables the UAV to perform its tasks for a while, to locate an alternate landing zone or to return to base.

Thus, the term 'mixed engine' does not stand for a hybrid drive, instead, it stands for a primary drive which operates in optimal conditions and a – temporary – secondary drive which may provides the capacity necessary for a limited period of time.

The following considerations should be addressed in order to decide on the appropriateness of a secondary engine:

- Extra weight triggered by the secondary system;
- Would an emergency landing be dangerous over a urban territory, or would an engine failure over enemy territory increase risks;
- Relative and overall increase in production costs;
- Overall reliability of the system.

A mixed engine shall be a system of utmost reliability, in order to comply with stringent licensing criteria.

The following is an overview of the types of engines adoptable in a mixed system:

Version	Engine	
	Primary	Secondary
1	IC piston engine	Electric motor
2	Electric motor	Electric motor

In the first case, when parameters indicate a failure of the IC piston engine (e.g. RPM drops below threshold, drop in exhaust gas temperature, drop in fuel consumption ... not in relation to control signs), the electric motor receives a signal right after the failed power supplier is disconnected from the driving line. Here it is important to provide the secondary electric engine with a power supply, which is distinct from the main electric lines, as a short circuit in the main power line would make the secondary electric motor dysfunctional.

The second option may be designed in a manner where in the course of normal operation the primary and the secondary electric motor operate together. In this case the secondary motor serves as a fallback system; this way the performance-to-weight ratio is more favorable. Independent emergency power supply and the disjunctibility of the driving line shall be made possible.

A summary of engines used in UAVs is as follows:

Type of air vehicle	Type of engine					
	IC piston engine	GT jet engine	Rocket engine	Electric motor	Chemical muscle	Mixed engine
Airship	+	-	-	+	-	-
With fixed wing	+	+	+	+	-	+
With rotating blade	+	+	-	+	-	+
Reciprocating wing	+	-	-	+	+	-

Conditions for selecting an engine

Operational parameters shall be determined during the selection process. These are the conditions, which may serve as a basis for designing the airframe and driving system of UAVs.

The above factors affect each other, so they cannot be treated separately. These factors can also be perceived as a multivariable function with a local maximum. Local maximums stand for possible solutions. Therefore, it is easy to see that for a certain task more air vehicles may be designed, differing in certain features.

Radius of action	Close (within 30 km)	Small (from 30 to 150 km)	Medium (from 150 to 650 km)	Large (above 650 km)
Flying altitude	Small (below 1000 m)	Medium (between 1000–6000 m)		High (above 6000m)
Cruising speed	Small (0-30 km/h)	Medium (between 30-400 km/h)		High (above 400 km/h)
Flying time	Tactical (under 24 hour)		Operational (more than 24 hour)	
Type of mission	Urban territory	Tactical	Operational	Strategic
Level of automation	Remote controlled ↔ Completely autonomous			
Payload	Light	Medium	Heavy	
Navigation during flight	VFR		IFR	

In general, it seems to be the case that those driving systems should be applied which have the smallest fuel consumption and the best performance, in a small-sized and light device. Such a seemingly simple task requires serious analysis. Assessing considerations of energetics, mechanical performance achieved using a larger engine operating at 2/3 of its capacity is preferred to the same level of mechanical performance provided by a smaller engine operating at full capacity. When selecting an engine, the aim is to have 15–20 per cent of the engine's capacity in surplus (reserve).

When the capacity of the engine chosen covers the capacity required for flight exactly, then the engine operates at full capacity throughout the mission. This is disadvantageous from the perspective of aeromechanics, engineering and energetics.

Considerations of aeromechanics call for reserve capacity that could even prevent the physical destruction of the aircraft in unexpected flight situations. This consideration is especially important in cases where the air vehicle carries expensive technical equipment.

A few considerations for selecting a driving system are as follows:

Performance-weight proportion ratio:

1. jet engine
2. IC piston engine
3. electric motor

Controllability:

1. electric motor
2. jet engine
3. IC piston engine

Reconnaissance (starting from best stealth features):

1. electric motor
2. IC piston engine
3. jet engine

Expenses (starting from lowest expenses):

1. electric motor
2. IC piston engine
3. jet engine

Undeniably, electric motors are winning the above race; despite their disadvantages, electric motors are being applied more and more frequently.

Examples of operating UAVs



Figure 13: SAS – type, a long range, multiple purpose UAV with 2 IC piston engines
(Designed by Electronic Warfare Department of MZNDU)



Figure 14: PREDATOR (Tier-2) operational reconnaissance UAV with IC piston engine driving rear pitch



Figure 15: EAGLE EYE STOL multi-purpose reconnaissance UAV with GT engine driving pitch



Figure 16: GT jet engine with propulsion and driving rotating wing



Figure 17: The Norwegian SRC UAV: single rear jet engine below it-and a conventional tail plane above



Figure 18: DELTA close reconnaissance UAV with electric driving pitch
(Designed by Electronic Warfare Department of MZNDU)

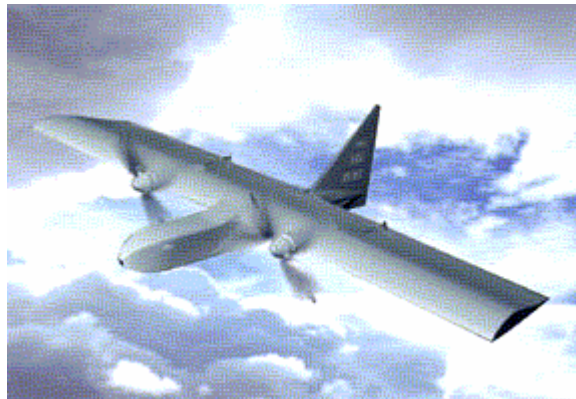

Figure 19: DRAGON EYE UAV with 2, 3-phase electric motors



Figure 20: Unmanned micro air vehicle

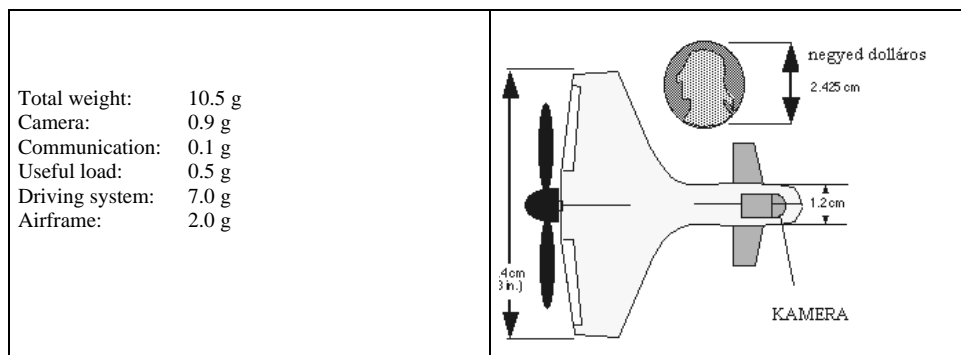

Figure 21: Unmanned micro air device

90 per cent of power stored on board is used by the driving system, while systems on board use the other 10 per cent of remaining power.

Factors endangering flight

Ornitological conditions

Since incidents with birds are practically impossible to avoid, all efforts should be made to minimize risks. On the basis of data provided by ICAO (International Civil Aviation Organization) 78 per cent of incidents registered took place at airports, or in their

closest proximity, while 22 per cent of incidents happened en route. An analysis of the height of these incidents reveals that 72 per cent of the events took place at ground level or low level. 60–80 per cent of the incidents happened below 500 meters, while 20–40 per cent of them happened below 1000 meters. As for the monthly distribution of incidents, events are rare at the end of winter and in early spring, while starting at the end of summer and in early autumn the frequency of events radically increases, a phenomenon, which might be explained with bird migration.

If the mission is at ground level or at low level, the risk of bird incidents is significant not only on takeoff but also at landing, and also during all other phases of the flight. The risk of events increases during high-speed missions at 100 m or below, as neither the operator nor the birds have an opportunity to avoid collision.

Any bird, independent of its size, may cause significant damage to the air vehicle. The larger the bird or the higher the flight speed, the damage resulting from the collision is more serious. Therefore, relatively large birds living in colonies mean the most serious risk.

It is wrong to believe that it is impossible to avoid ornithological events. In order to seek protection against birds, or to minimize the possibility of collision, it is of utmost importance to learn about the habits and life-style of birds living at or migrating in the proximity of the operational area as professionally collected and analyzed data on bird collisions provide important information on zones of interest. The Bird Monitoring Program aims to explore the habits, composition and size of bird populations on territories of interest. This is the first phase of a more comprehensive program aiming to reduce the risk of air vehicle – bird collisions and thus seeking to enhance flight safety.

Meteorological conditions

Icy conditions: freezing of atmospheric water on various parts of the air vehicle, especially on parts exposed to air flow. Icy conditions may occur throughout the year, when flying in a cloud the temperature of which is below 0 °C. Ice thus deposited alters the airflow around the airplane, reduces the performance of the engine and endangers flight. The diminution of flight characteristics of the aircraft depends on the amount of ice deposited, the shape, surface and air speed of the aircraft. In case of UAVs excess weight due to ice deposition and the damage to aerodynamic features together may make the air vehicle incapable to perform its tasks, since UAVs do not have a significant amount of reserve capacity required in such cases. Anti-icing or de-icing systems might be viable solutions, provided that they are based on a heat-pipe collector as it utilizes warm products of combustion, thus it does not impose significant extra

weight, nor does it require additional power supply. Freezing may start at +15 °C inside a jet engine, at the intake pipe or in an IC piston engine at the suction port.

Wind: maximum wind strength shall be defined for each UAV at which safe takeoff and landing, as well as a secure performance of mission might be performed. As a general rule, takeoff and landing may be performed if the stalling speed of the air vehicle approaches the base of wind strength to 60 per cent, and the gust of wind to 90 per cent. Wind strength shall not exceed 50 per cent of the cruising speed at any height during flight. When planning the mission data on wind strength and direction shall also be considered for determining the required amount of fuel.

The other component of wind is turbulence. In case of UAVs turbulence becomes a factor when vortex size is matched with the wingspan of the air vehicle (b) (0.5·b–0.8·b). Vortexes smaller than this do not affect the air vehicle, while in the case of larger vortexes it is the operator's task to react to the wind via maneuvering.

Depending on the kind and intensity of turbulence, the type, speed and load of the air vehicle the following may take place: the air vehicle becomes uncontrollable, or the capacity of the driving system becomes insufficient for horizontal flight, resulting in a drop of air speed, controls becoming unreliable, or due to random alterations in external aerodynamic forces the overcharge may result in permanent deformation, or a catastrophic fracture.

In order to avoid flights in turbulence the operator shall be familiar with the circumstances and factors triggering turbulence. This way potentially turbulent zones are more likely to be avoided.

Precipitation: hailing may cause significant mechanical damage to the driving system and the airframe; therefore, flights in hailing should be avoided. In case showers are not accompanied by thunder, major difficulties may primarily stem from serious rains hindering orientation, damage to the electric system, or the IC piston engine being overcooled.

Clouds: thunders – occurring mostly during the summer – are the most dangerous components of weather from the perspective of air traffic. Electric phenomena in the atmosphere, particularly strong winds, turbulences, wind shear, microburst, heavy hailing, icing in the thundercloud are all features of a thunderstorm that are certain to extinguish a UAV. No flights should be scheduled in such circumstances.

Solid particles in the air: volcanic ash, sand and dust may all damage an IC piston engine or a jet engine. These may cause unintended residue or erosion and abrasion that might significantly reduce the operating time of the air vehicle.

Personnel: training and practice may reduce the significance of the human factor.

Stealth technology

*If they cannot see it and cannot hear it,
they cannot detect it.*

Stealth technology became crucial for UAVs due to the evolution of precision weapons. Evidently, one has to consider such technologies that do not result in a radical increase of expenses, as one of the major advantages of UAVs is their relatively low cost – compared to traditional measures.

Beyond traditional means of visual and audio reconnaissance, intelligence is gathered via locators, lasers and thermo-pelengators. Therefore, new technologies preventing detection became a must. Special materials were used for the airframe to build certain UAVs with stealth technology. This enables the UAV to enter the flight zone of the opposing party without the air defense systems of the latter being alerted.

Stealth technology does not simply stand for a technology or material; rather, it means the complex practical application of such theories, technical solutions and materials, with the help of which the air vehicle is completely or essentially undetected by all means of detection, in the full spectrum of detection.

In the following I summarize those aspects of stealth technology that are applicable to driving systems. It is possible to obtain information in a wide frequency range about traditional air vehicles:

- Light and radio waves reflecting from reflective surfaces of the engine;
- Heat and noise generated by the engine, condensation trail and turbulences are the easiest to detect.

As a result, air vehicles built with stealth technology shall comply with the following:

- The surfaces of the engine reflecting locator-waves shall be reduced, via designing such a physical shape, materials and equipment which have low reflection features, and absorb most or all locator-waves;
- Heat, electric, magnetic, light and noise waves emitted by the air vehicle and its systems shall be minimized to the farthest extent possible.

In the light the above the following solutions might be relevant. An analysis of radio detection patterns of air vehicles of various size and structure revealed that the strongest signals are reflected by the airframe's large, connected and even surfaces (in the case of UAVs this means nacelle, inner and outer surfaces of intake pipes, first gage of compressor). As reconnaissance depends on the object's effective reflecting cross-section it is practicable to place the engine inside the fuselage, and to place the intake cross-section of the intake pipe on the upper section of the fuselage (this solution,

however, reduces the capacity of the driving system). It is advisable to provide metallic surfaces located under coatings, which are permeable to radio waves (e.g. main parts bearing load) with a coating of internal through-reflection.

The air vehicle's primary sources of the heat emission are its operating driving system and its exhaust pipes, with exhaust gases; this heat may be reduced most efficiently via using circumstantial air for cooling. A further means of reducing traceable heat emission includes adding an exhaust pipe with an adjustable cross-section and a heat exchanger grid on the upper part of the fuselage (preferably between the fins). The latter solutions may supplement each other.

Visual exposure may be further reduced with preventing the formation of a condensation trail via adding chloride-fluoride-sulfonic acid to the exhaust gases. Note that exhaust gases will be traceable in ultra-viola light.

Noise induced by the air vehicle might be reduced on various ways. In this case the source of noise is an object moving in the noise area. Sound is primarily induced by the engines, propellers and rotating wings of the air vehicle, and streams around the air vehicle.

In the case of UAVs with GT jet engines sound emission levels are predominantly affected by the noise generated by the various parts (units) of the engine, i.e. compressor, turbine, blades, intake and exhaust pipe, and combustion chamber.

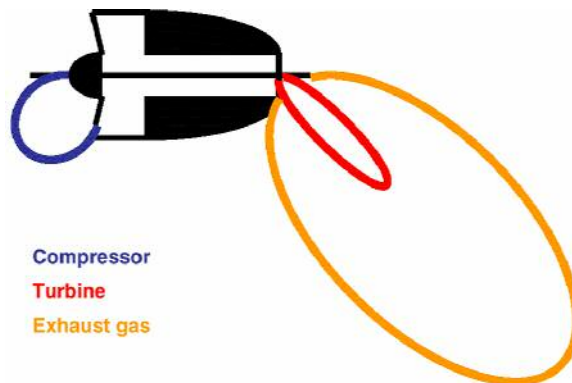

Figure 22: An EPN (Equivalent Pressure Noise) chart of the units of the jet engine

The relationship between the gas dynamics parameters of engines and noise induced by the various systems of the air vehicle can be described by empirical formulas based on research and empirical measurements.

There are various solutions for placing the driving system on UAVs with GT jet engines and propulsion drives:

- Engine nacelle above fuselage;
- Engine nacelle integrated in fuselage;
- Engine nacelle below fuselage.

In case of UAVs a nacelle integrated in the fuselage is an optimal solution, as the required sound absorption layer may also serve as the coating of the air vehicle. Considerations of aerodynamics also support this solution.

Thereupon one may find that it is possible to achieve proper sound absorption, sound proofing and optimal aerodynamic solutions on the engine and other parts of the air vehicle.

The level of noise induced by the air vehicle is fundamentally affected by the capacity of the engine, the weight of the air vehicle and its flight procedure. In case of any UAV such techniques of noise reduction should be developed for each device to allow for an optimal engine-to-capacity ration for each task. Examples may be found in the course of computerized preparations on the ground and application of on-board computers.

In addition to the engine the propeller, the rotating blade, aerodynamic surfaces, parts and equipment also induce aerodynamic noise. The operation of propellers and rotating blades induces significantly more sound than the aerodynamic surfaces. For the purposes of noise reduction the most optimal solution for an air vehicle with rotating wings is a rotating wing with 5-6 blades as also recommended by ICAO, with NOTAR torque equation.

Questions of maintenance

The following duality can be traced in the development of UAVs. In certain cases its application requires that the operation of the UAV should not depend on trained personnel (e.g., micro UAVs at infantry units). Certain tasks, however, can only be resolved by modern, complex systems where a mission requires the cooperation of an entire team of trained professionals (e.g., in the case of RQ-1A Predator a personnel of 38 participates in a mission, including 6 technicians). As that was already demonstrated, one must also mention maintenance skills that are familiar from traditional aircraft maintenance.

Full-scale maintenance takes a technician who:

- Knows the aircraft, its systems and operation, and is able to perform preparation, maintenance and repair works;

- Is able to combine high-level skills in aviation-technology, computer and controlling;
- Is familiar with technical and operational planning and performance;
- Has to assist the aircraft with such care and responsibility, as is maintaining manned aircraft.

The application of UAVs for reconnaissance purposes is the outcome of a complex procedure, which consists of the following components:

- Planning the route and tasks of the air vehicle;
- Preparing the air vehicle for the tasks, placing payload on the air vehicle (electro-optical reconnaissance sensors, interruption equipment, radio-locator, etc.), programming data required for flight (route, height, etc.);
- Takeoff or launching;
- Flight to the operating territory (in an autonomous manner or via remote control);
- Performance of mission: detection of target, identification of target, following target, transmitting reconnaissance data to mission center on ground;
- Receiving and analyzing mission data at mission center, preparation of report;
- Returning air vehicle to landing zone;
- Landing air vehicle.

In short, maintenance personnel shall have full-scale technical and operational skills and knowledge.

Final conclusion

With the application of advanced technology and technological developments driving systems of UAVs are rapidly improving. For the future development of the driving systems of UAVs, the following considerations are controlling:

- Improve technician parameters;
- Easy and inexpensive operation;
- Modest logistic support requirements;
- Easy transportation;
- Advanced anti-reconnaissance features;
- Additional supply of electric energy for systems (payload) on board;
- Cost efficiency.

References

- KESZTHELYI, GY., ÓVÁRI, GY.: A Stealth technológia hatása a XXI. század katonai repülőeszközeinek alkalmazhatóságára, *Repüléstudományi Közlemények*, XII (29) (2000).
- KOVÁCS, I.: A repülőgép madárral történő ütközése, mint a repülés biztonságát befolyásoló tényező, *Repüléstudományi Közlemények*, XII (29) (2000).
- MAKKAY, I.: Az elektronikai hadviselés modern eszközei, rendszerei a Magyar Honvédség haditechnikai korszerűsítésének tükrében. Légi robotok a XXI. Századi hadszíntéren.
- MAKKAY, I., VÁNYA, L.: Harcászati hadműveleti pilóta nélküli repülőeszközök, *Nemzetvédelmi Egyetemi Közlemények*, 2 (1) (1998).
- MARTON, CS.: A pilóta nélküli repülőeszközök alkalmazása elektronikai felderítési feladatokra, *Repüléstudományi Közlemények*, XII (29) (2000).
- MARTON, CS.: Légi felderítés robotokkal, II. rész, *Hadtudományi Tájékoztató*, 2001 (6).
- NÉMETH, M.: Gázturbinás sugárhajtóművek áramlástanai vizsgálata a légi járművek által keltett zaj csökkentése céljából, *Repüléstudományi Közlemények*, Különszám I (2001).
- PALIK, M.: A pilóta nélküli repülőeszközök civil alkalmazásának lehetőségei, *Repüléstudományi Közlemények*, XII (29) (2000).
- SZILVÁSSY, L.: Repülőgép-fedélzeti rakéták hajtóműveiben alkalmazott hajtóanyagok, *Repüléstudományi Közlemények*, X (25) (1998/2).
- SZILVÁSSY, L., BÉKÉSI, B.: Rakétahajtóművek, *Repüléstudományi Közlemények*, XI (26) (1999/1).
- VÁNYA, L.: Pilóta nélküli felderítő repülőgépek fejlesztésének lehetőségei, (A 2002-es gödi konferencia írásos anyaga).
- VARGA, B.: Noise reduction methods of modern single rotor helicopters, *Bulletins in A. S. XIV*, 1 (2002).